

979-CT Specification

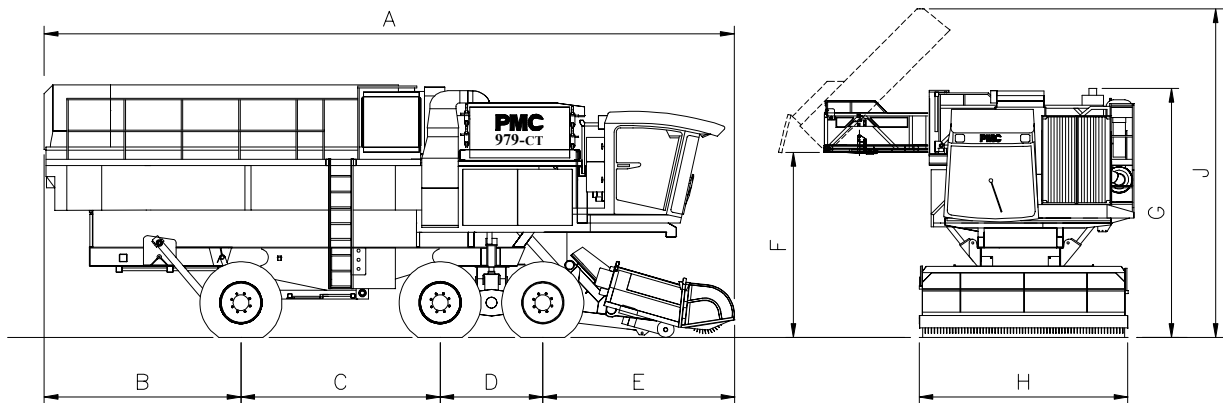

Side & Front elevation of machine

Main dimensions

Length	a	11975
Overhang	b	3555
Wheel centres	c	3350
Wheel centres	d	1550
Overhang front	e	3520
Discharge height	f	2830
Height (level)	g	4150
Height (road, rear m/c down)	g	4000
Height	j	5300
Width	h	3500/4000
Width outside tyres		3224

Weights (on the road)

	kg
Front axle	8360
Centre axle	8360
Rear axle	9400
Total (approx)	26120

Weights (on the field) kgs

Front axle	8800
Centre axle	8800
Rear axle	8520

Fluid capacities

Fuel	775 litres
Hydraulic oil	550 litres
Hydrostatic tank	110 litres

Tyres

Trelleborg Twin Radial	680/55 R 26.5
Static loaded radius	0.63m
Rolling circumference	4.21 m
Pressure: Front Bogie	2.0 bar
Rear Axle	2.2 bar

Engine

Make	Deutz liquid cooled
Type	TCD 2015 V06
Power rating	300kw (ISO 3046)
Capacity	11.906 litres

Transmission

Type	Hydrostatic
Pump	S-D 90/130 cc/rev
Motors (front)	Poclain S18
Motors (rear)	Poclain S18
Motor displacement	1501/545cc

Vehicle speeds

Road	25 kph
Field	9 kph

Hopper capacity

Volume	3.1 m ³
Weight of peas	1900 kg(approx)

Levelling

Front to rear	15% (8.5°)
Side to side	18%(10.2°)

979-CT with Tracks Specification

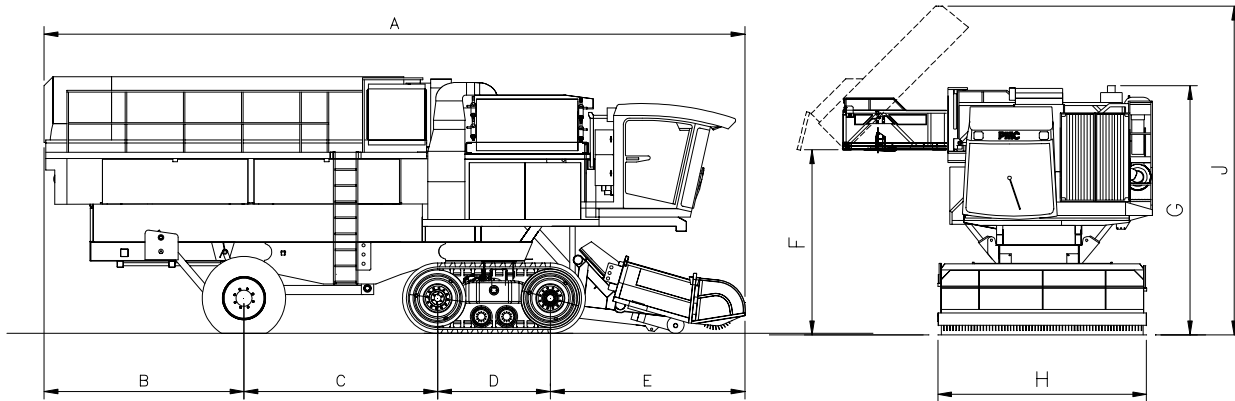

Side & Front elevation of machine

Main dimensions

Length	A	11975
Overhang	B	3555
Wheel centres	C	3140
Wheel centres	D	1825
Overhang front	E	3455
Discharge height	F	2830
Height (level)	G	4150
Height (road, rear m/c down)	G	4000
Height	J	5300
Width	H	3500/4000
Width outside tyres / tracks		3224

Weight (on the road)	kgs
Total (approx)	28260

Fluid capacities

Fuel	775 litres
Hydraulic oil	550 litres
Hydrostatic tank	110 litres

Tyres

Trelleborg Twin Radial	680/55 R 26.5
Rear Axle	2.2 bar

Engine

Make	Deutz liquid cooled
Type	TCD 2015 V06
Power rating	300kw (ISO 3046)
Capacity	11.906 litres

Transmission

Type	Hydrostatic
Pump	Sauer Danfoss
	S-D 90/130 cc/rev
Rear AxleMotors	Poclain S18 (2)
Front Axle Motors	Sauer Danfoss (2)

Levelling

Front to rear	15% (8.5°)
Side to side	18% (10.2°)

Vehicle speeds

Road	25 kph
Field	9 kph

Hopper capacity

Volume	3.1 m ³
Weight of peas	1900 kg(approx)

PMC Harvesters pursues a policy of continuous product improvement and reserves the right to change specifications, models and designs without notice or obligation.